





ASSEMBLY INSTRUCTIONS

RANGE	Elect Coffee, Meeting and Poseur Tables	
REF:	Coffee Table, Round and Square Top 600 and 800mm wide, Meeting Table Round and Square Top 600 and 800mm wide, Poseur Table Round Top 600mm wide.	
	 Read this leaflet before assembly	 2 People Required

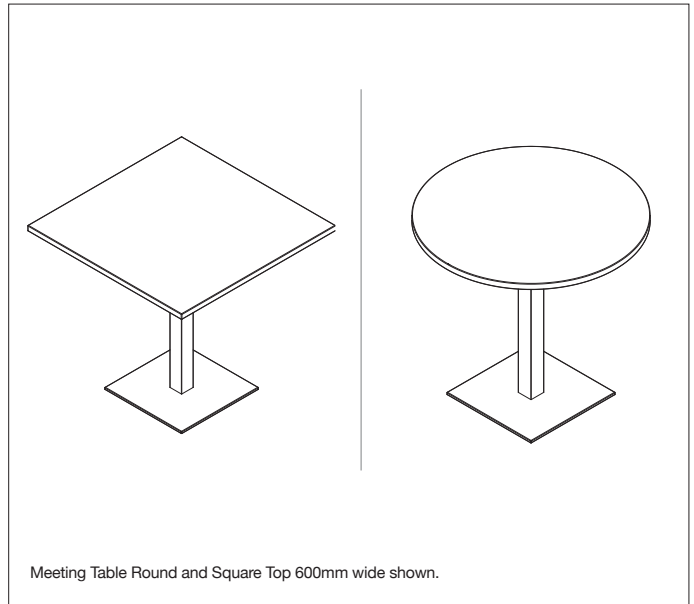

COMPONENT PARTS

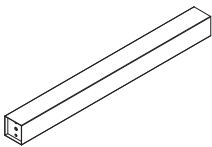

Item 1
Brushed S/Steel Upright Leg
Qty,1
A/1785, A/1786, A/1787

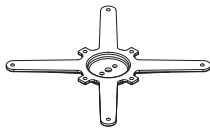

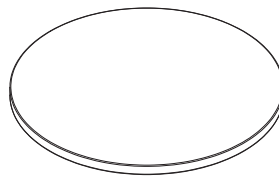

Item 2
X-Frame
Qty,1
A/1785, A/1786, A/1787

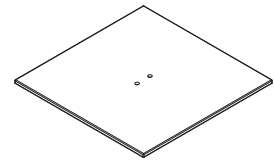

Item 5
Elect Table Top
Qty,1
1222, 1223, 1224, 1225

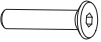

Item 6
Base Plinth
Qty,1
A/1785, A/1786, A/1787

 Item 3 Hex Head Screws Qty 4 A/1785, A/1786, A/1787	 Item 4 3/4" x 10g Pan Pozi BZP Qty 8 F/0475					
--	--	--	--	--	--	--

TOOLS REQUIRED BEFORE YOU BEGIN...

- Pozi head screwdriver
- Check you have all the tools and components required
- Keep children and animals away from small parts
- Ensure you have adequate space
- Assemble product on a flat, clean surface
- Apply manual handling guidelines when building this item

ASSEMBLY INSTRUCTIONS

STEP 1

Hold the Upright Leg (1) vertically. Both ends are identical so it does not matter which end is up. Place the X-Frame (2) onto the Leg and attach it with Screws (3). Fully tighten the Screws.

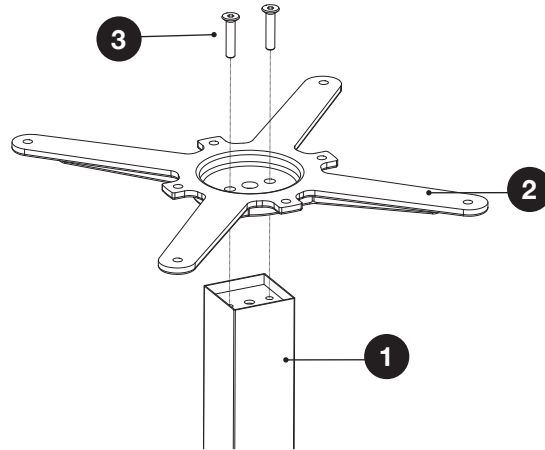

STEP 2

Lay the Top (5) upside down on a flat, soft surface. Ensure all holes are free of debris. Turn the Leg upside down and align the Holes in the X-Frame (2) with the Pilot Holes in the Top (5). Attach the Leg to the Top with Screws (4). Do Not Tighten any Screws until all Screws are in place. Fully tighten the Screws.

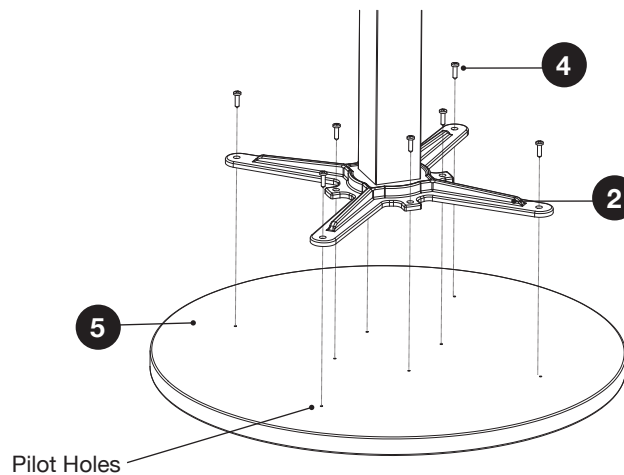

STEP 3

With the Table/Leg assembly still on the floor, attach the Base Plinth (6) to the Leg with Screws (3). Fully tighten the Screws. Turn the Table the right way up.

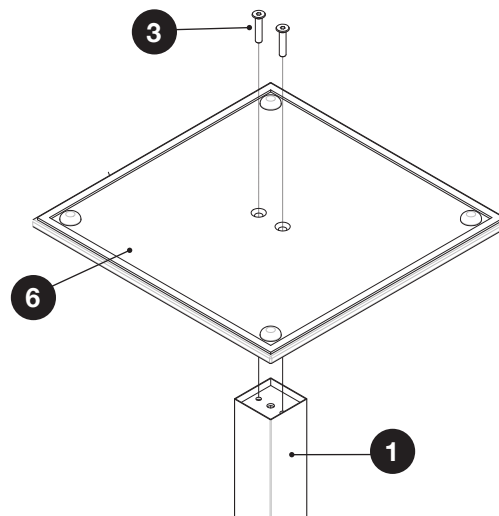

CARE AND MAINTENANCE

Clean using a damp cloth and mild detergent – do not use abrasive cleaners or bleach.