













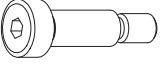
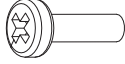

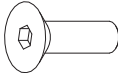
**ASSEMBLY INSTRUCTIONS**

<b>RANGE</b>	InMotion Double Manual	
<b>REF:</b>	1200, 1400, 1600, 1800mm Wide.	
	 Read this leaflet before assembly	 2 People Required

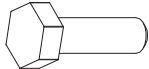

**FIXINGS**

 <b>Item 1</b> F/0664 M8x10 Socket Shoulder Screw Qty 8	 <b>Item 2</b> F/0415 M6x20 Pan Pozi Bzp Qty 8	 <b>Item 3</b> F/0591 5x70 Pan Head Bzp Qty 8	 <b>Item 4</b> F/0665 M6x20 Csk Socket Screw Bzp Qty 16	 <b>Item 5</b> A/2175 Double Collar Bush Qty 4
 <b>Item 6</b> A/2174 Large Spring Clip Qty 2	 <b>Item 7</b> A/2173 Spring Clips Qty 12	 <b>Item 8</b> F/0475 3-4 x 10g Pan Pozi Bzp Qty 24	 <b>Item 9</b> A/2176 M5x4mm Grub Screw Qty 12	 <b>Item 10</b> A/2177 Bung Qty 2
 <b>Item 11</b> A/2172 Flange Sleeve Qty 12	 <b>Item 12</b> F/0662 M6x20 Hexagon Bolt Bzp Qty 16			

**TOOLS REQUIRED**

- Pozi head screwdriver
- 2.5mm Allen key
- 5mm Allen key
- 4mm Allen key
- 10mm spanner

**BEFORE YOU BEGIN...**

- Check you have all the tools and components required
- Keep children and animals away from small parts
- Ensure you have adequate space
- Assemble product on a flat, clean surface
- Apply manual handling guidelines when building this item

# ASSEMBLY INSTRUCTIONS

## STEP 1

Lay the desktop upside down on a flat, clean and soft surface.

Attach the crank brackets to the leg columns using screws (4).

**Note:** Ensure one of the holes in the leg column is facing as shown below.

When attaching the column leg to the bracket the sticker on both legs should face towards the bar at the back of the desk.

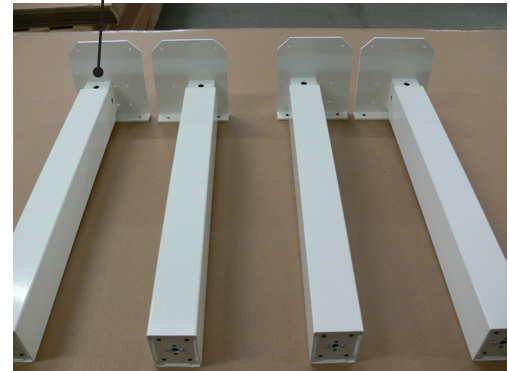
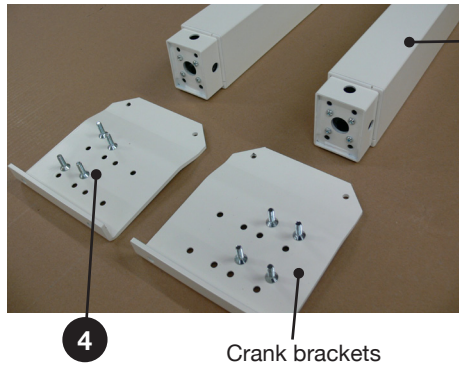

## STEP 2

Attach the foot plate to the leg columns and tighten the bolts (12) (only finger tight at this time).

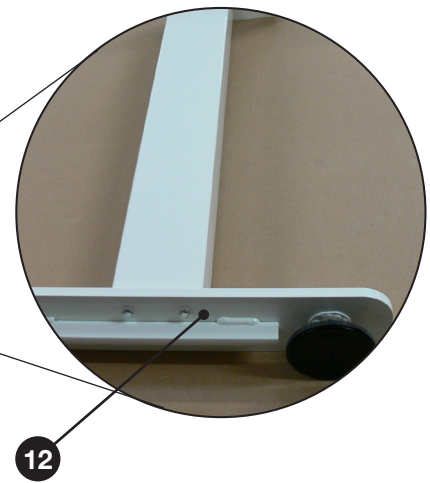
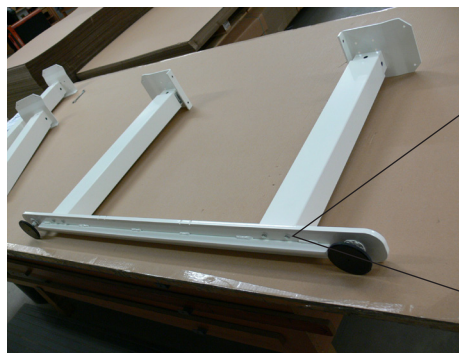

## STEP 3

Attach the rail using the shoulder screws (1).

**Note:** Screw holes for the cable trays must be at the bottom of the rail and point towards the back of the desktops.



Screw holes for the cable trays must be at the bottom of the rail and point towards the back of the desktops.

## ASSEMBLY INSTRUCTIONS

### STEP 4

Attach spring clips (**7**) and washers (**11**) to the longest hex rods and insert them into the holes in the leg columns. Fix the spring clips (**7**) and washers (**11**) on the out side of the legs.

Slide the two aluminium tubes over the rods.

Place the small hex rod between the two aluminium tubes and tighten into position using the two grub screws (**9**). Then use the four remaining grub screws to tighten the completed bar assembly in place.

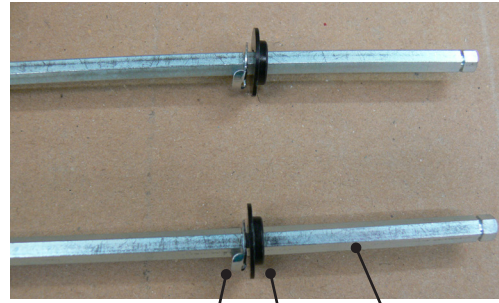

7

11

Long hex rods

Aluminium tubes

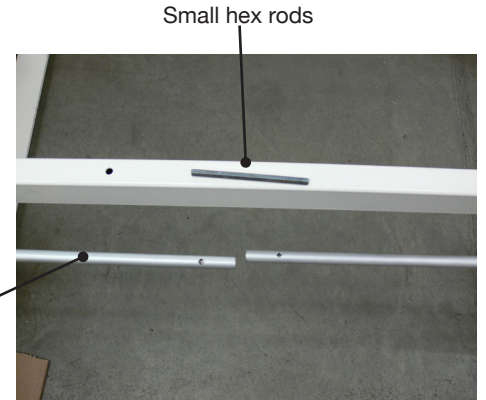

Small hex rods

### STEP 5

Attach the left and right side plates to the underside of the desktop using screws (**8**).

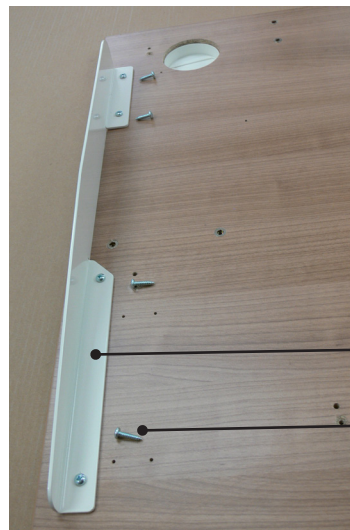

Side plates

8

### STEP 6

Attach the handle bracket to the underside of the desktop using screws (**8**) (on the left or right as required).

Clip the two collars (**5**) to the handle bracket.



handle bracket

5

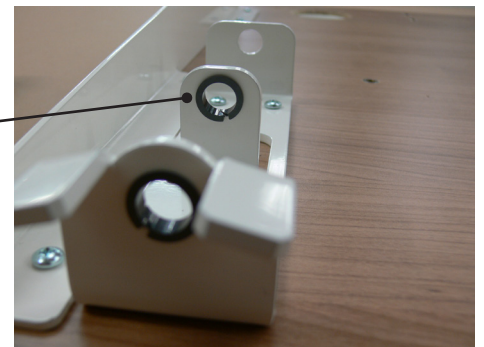



## ASSEMBLY INSTRUCTIONS

### STEP 7

Using two people, carefully place the desktop on one of the leg sets and screw down using (3) + (2).

### STEP 8

Slide the medium hex rod through the handle bracket.

Then slide a plastic washer (11) on the hex rod, ensuring the flat sides face each other.

Clip the two smaller spring clips (7) to the hex rod. The spring clip lugs must face one another.

Insert the hex rod into the InMotion leg via the hole.

Slide the handle over the hex rod and clip on the large spring clip (6).

Insert the bung (10) into place on the leg column hole that is not being used.

**Repeat steps 5 to 8 with the second desktop.**



### STEP 9

Tighten the bolts (12) on the foot plates using a spanner to ensure the desks are in alignment.



## CARE AND MAINTENANCE

Clean using a damp cloth and mild detergent – do not use abrasive cleaners or bleach.