





### ASSEMBLY INSTRUCTIONS

RANGE	Signature	
REF:	Espagnolette Lock System	
	 Read this leaflet before assembly	 1 Person Required



### ESPAGNOLETTE - SCREW FIXING

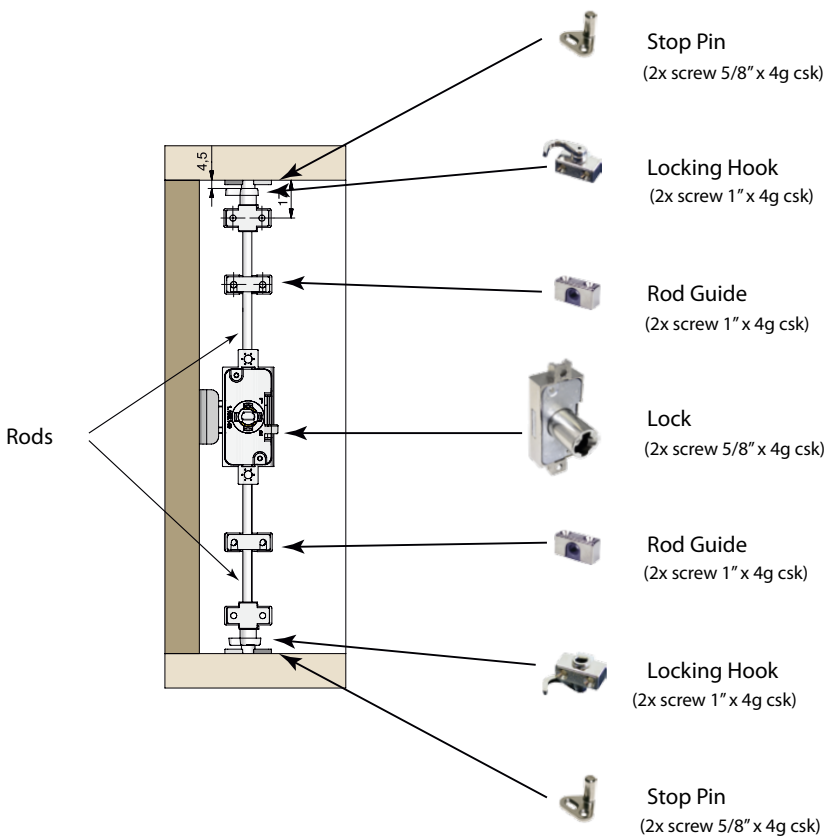

### TOOLS REQUIRED

- Pan head screwdriver

### BEFORE YOU BEGIN...

- Check you have all the tools and components required
- Keep children and animals away from small parts
- Ensure you have adequate space
- Assemble product on a flat, clean surface
- Apply manual handling guidelines when building this item

## ASSEMBLY INSTRUCTIONS

### STEP 1

- A** Screw the Door Stops to the Top & Base in the pair of holes further apart. Ensure the vertical part is set to the outside.  
(2x screw 5/8" x 6g pan head)
- B** Screw the Stop Pins to the Top & Base in the pair of holes close together. Ensure the pin is set to the inside.

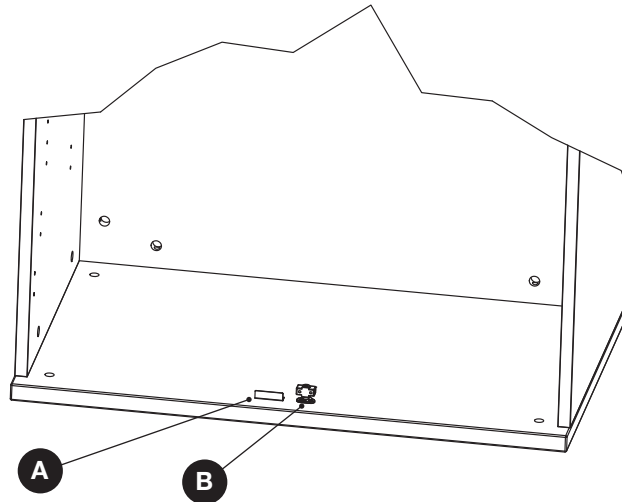

### STEP 2

- A** Screw the Z shaped door catch on the Left Hand door with screws in the holes furthest from the edge.  
(2x screw 5/8" x 4g csk)

