

Important Information

This instruction leaflet is suitable for building the DOMINOBEAM Crescent desk.





Safety Guide

- The overall weight of the complete item is + 51kg. Apply manual handling guidelines when building this item.
- Only use component fixings supplied with this item.
- Build product on a flat surface.

Parts Required

- A**  **Zinc Insert**
Code: F0594 Quantity = 2
- B**  **M6 x 25mm Socket Cap BZP**
Code: F/0618 Quantity = 4
- C**  **M6 Spring Washer**
Code: F/0608 Quantity = 4
- D**  **M8 X 30mm Countersunk BZP**
Code: F/0604 Quantity = 3
- E**  **4mm x 25mm Flange Pozi (Black)**
Code: F/0453 Quantity = 2
- F**  **Plastic Beam Spacer**
Code: F/0593 Quantity = 2
- G**  **M6 x 12 Socket Head**
Code: F/0605 Quantity = 2
- H**  **Zinc Nut**
Code: F/0494 Quantity = 2
- I**  **10 x 3/4 Flange Pozi S/Tap BZP**
Code: F/0619 Quantity = 15

Tools needed

-  **Pozi Head Screwdriver**
Quantity = 1
-  **4mm Allen Key**
Quantity = 1
-  **5mm Allen Key**
Quantity = 1
-  **10mm Spanner**
Quantity = 1

DOMINOBEAM Assembly Instructions

1. Locate part **A**, a Zinc Insert, into one end of each Beam Crossrail, insert this to achieve either a left or right hand Beam.
2. Remove Top Plate from both upright Beam legs provided. These are secured by 2 screws, part **B** and washers part **C**. Put these to one side for later.
3. Holding the Round Column Leg upright slot one Crossrail Extension onto the screw protruding from the column leg. Ensure the open side of the rail faces the front of the desk and tighten once fitted using the 4mm Allen Key. Repeat process with second Crossrail Extension.
4. Attach the square plate, using part **D**, to the Column Leg.
WARNING If assembling more than one desk please refer to full Plus 1 instructions (No. 098).
5. Place the desk top face down on the floor. Take the completed Column leg turn upside down and screw onto the desk top using part **I**.
6. Stand the Beam leg upright and slot the Beam Crossrail into the leg, as shown in position 1, ensuring the open side of the rail faces the front of the desk and the access hole for the Beam Spacer is facing the floor.
7. Re-attach the Top Plate using part **B**, screws, each with a washer, part **C**. Place the first screw in the rear hole to ensure the correct positioning of the Top Plate.
WARNING It is important to ensure the top plate is 90 degrees to the Beam Crossrail, so that the screw holes line up with the desk top holes.
8. Flip the leg upside down and slide the Beam Crossrail into the left hand Crossrail extension. Repeat steps 6, 7 and 8 for the remaining i-frame Beam leg and Return Beam Crossrail.

Continue overleaf

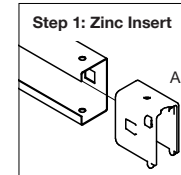
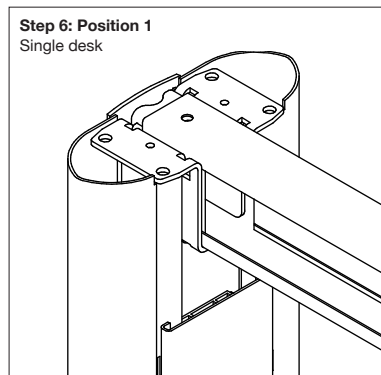
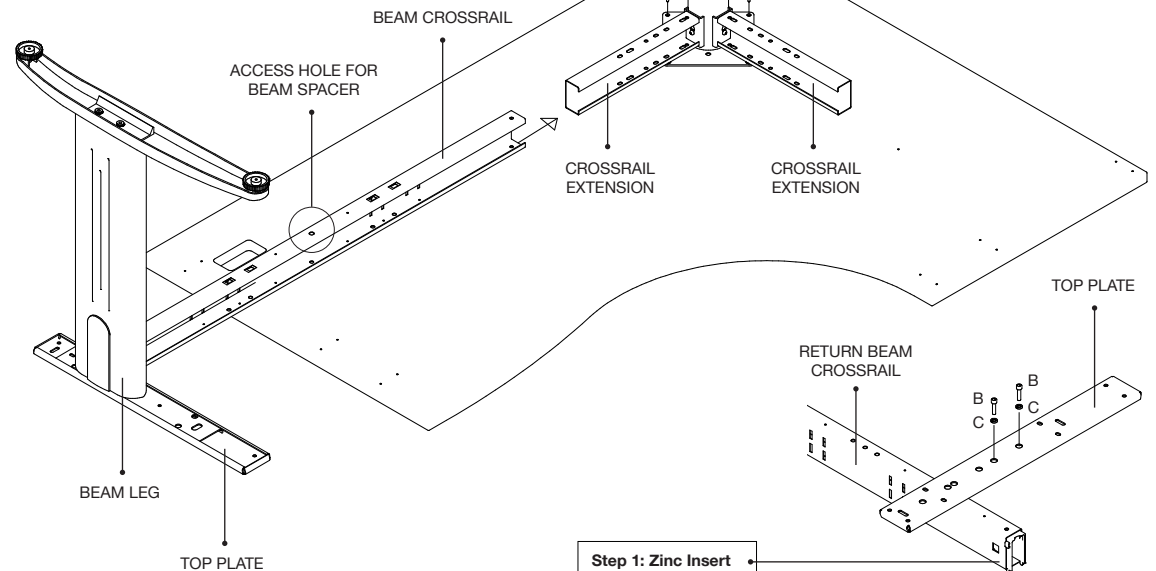
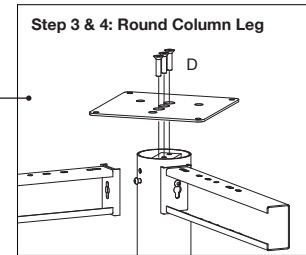
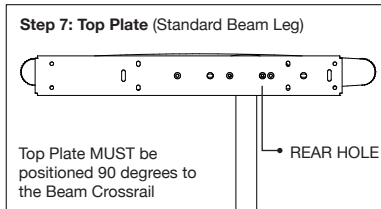

LEFT HAND DESK SHOWN

9. Use part **G** with part **H**, zinc nut, to secure the Beam frame where the two sections slide together.
10. Using part **E** attach both plastic Beam spacers, part **F**, loosely.
11. Secure the desk top to the frame using part **I**. Line up the screws and hand tighten until all screws are located in the correct places.
12. Tighten all parts **I** and then secure the Beam Spacer to the desk top.
13. Flip desk into the upright position.
14. At this point adjust the feet to ensure the product is level, this can be done by hand.
15. The Beam desk is now complete.

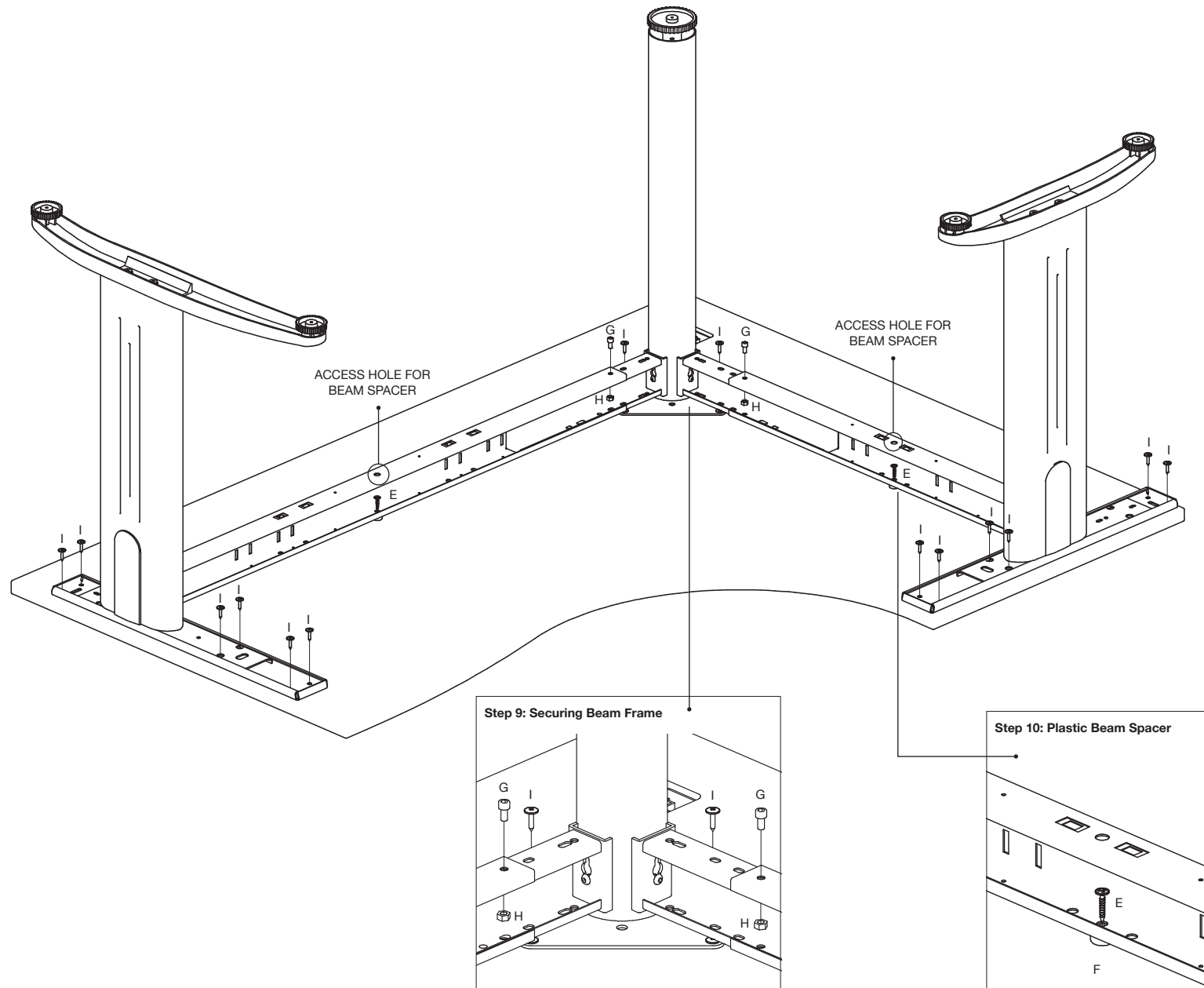

Hints & Tips

Cable Management

Once the Beam desk is complete, simply feed the wires that you require to run through the desk via the cable ports and down through the cable trunking in the legs. Optional horizontal cable management is available upon request and this simply fits into the open side of the Beam Crossrail. Access points to the Beam leg are located behind the inner and outer cover plates.