

**Important Information**

This instruction leaflet can be used for the AURA BENCH cable tower only.

**Safety Guide**

- Apply manual handling guidelines when building this item.
- Only use component fixings supplied with this item.

**Recommendations**

**Attaching the Cable Tower**

It is advisable to connect the cable tower to the Bench desk during the build up stages before the desk tops have been secured to offer best access.

It is possible to add the cable tower to a completed Bench desk, simply use the cable management port holes as access points.

**Cable Tower Assembly Instructions**

1. Clip part **A** into place on the inside of the cable tray.
2. Position the cable tower underneath a downward facing porthole in the Bench system cable management. Using part **B**, screw the cable tower into place through the top of the cable management.
3. Once the cable tower is secure feed the wires through the cable clips to the floor. Using Part **C**, and secure the wires in place at the bottom using the cable clamps, part **D**.
4. Take the cable tower cover and slot this over the pin located on the side of the cable tower and offer up the cover to the cable management until this clips into place.
5. The AURA BENCH Cable Tower is now complete.



1 Person Required

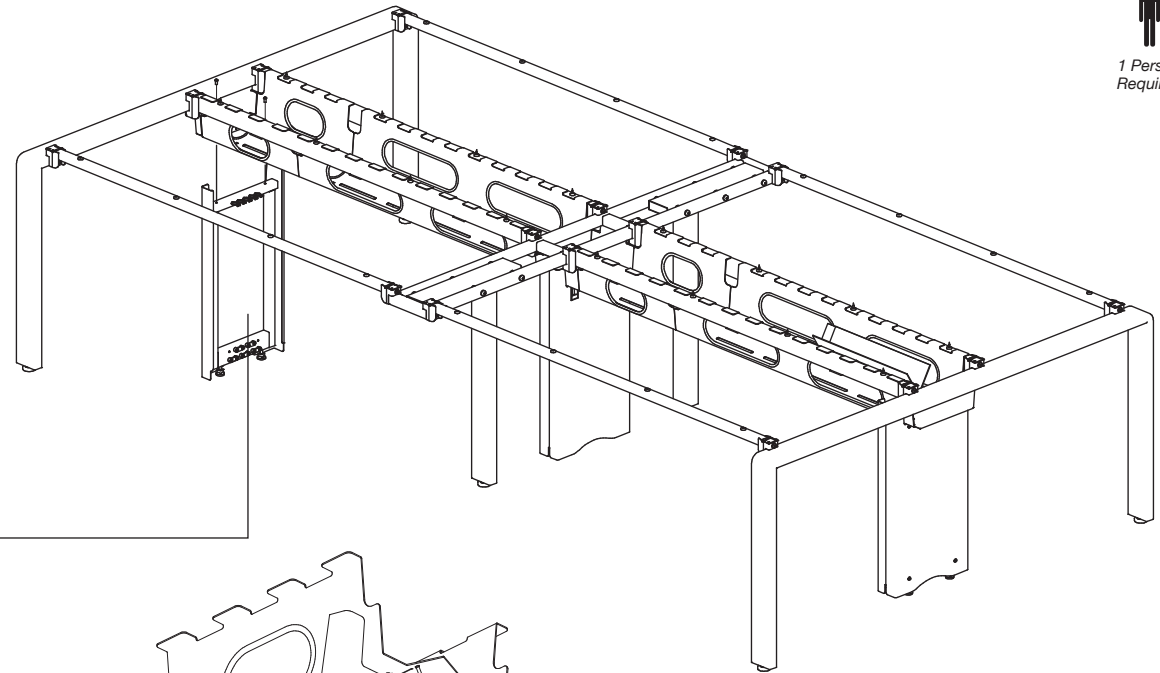

**Parts Required**

- A** **Cable Clip**  
Code: F/0617 Quantity = 5
- B** **M6x12mm Button Screw**  
Code: F/0603 Quantity = 2
- C** **Cable Clamp**  
Code: F/0496 Quantity = 5
- D** **1" x8g Pozi-Flange Screw BZP**  
Code: F/0474 Quantity = 10

**Tools needed**

- Pozi Head Screwdriver**  
Minimum 200mm long Quantity = 1
- 4mm Allen Key**  
Quantity = 1
- 12mm Spanner**  
Quantity = 1

