

Important Information

This instruction leaflet can be used for the AURA BENCH rectangular or wave set of 4, set of 6 and set of 8 desk configurations.

Safety Guide

- Apply manual handling guidelines when building this item.
- Only use component fixings supplied with this item.

Recommendations

Levelling the Bench desk

It is important to adjust the feet at the start and finalise at the end to ensure the product is level. To do this simply use a 12mm Spanner to adjust the feet to the appropriate height. See step 12.

Screens





If using screens please remember that screens are to be added at the point the tops are secured to the frame. These cannot be added at a later stage. See step 11.





AURABENCH Assembly Instructions

1. Compile Set 1 (S1) and Set 2 (S2) screws, using parts A, B, C and D. These are required to fit the Bench frame together.
2. If building a wave desk (800mm deep desks only) please ensure the intermediary leg is reversed. This will offer extra support. (See reverse)
3. Holding one end frame upright, slot the centre crossrails in place first locking one end into the leg frame and the other into the intermediary leg. Use parts S1 to loosely secure these in place. **WARNING Do not fully tighten screws at this stage.**
4. Place the outer crossrails into position connecting the end frame and intermediary leg using S2 screws. Fully tighten all S1 and S2 screws.
5. Repeat this process with the opposite outer leg frame. Continue this process as necessary for the set of 6 and set of 8 bench desk configurations.
6. Attach the cover plate using parts S1.
7. Insert glide buffers, part E, into the holes in the crossrails.

Continue overleaf

Parts Required

- A**  **M8 x 50mm Skt Button BZP**
Code: F/0597 Quantity = 24 (set of 4)
Quantity = 36 (set of 6)
Quantity = 48 (set of 8)
- B**  **M8 x 25mm Skt Button BZP**
Code: F/0589 Quantity = 8 (set of 4)
Quantity = 12 (set of 6)
Quantity = 16 (set of 8)
- C**  **M8 x Contact Spring Washer**
Code: F/0542 Quantity = 32 (set of 4)
Quantity = 48 (set of 6)
Quantity = 64 (set of 8)
- D**  **M8 Plain Washer BZP 8mm x 17 x 1.6**
Code: F/0598 Quantity = 32 (set of 4)
Quantity = 48 (set of 6)
Quantity = 64 (set of 8)

- E**  **Glide / Buffer Drilled 15mm x 18mm**
Code: F/0606 Quantity = 32 (set of 4)
Quantity = 48 (set of 6)
Quantity = 64 (set of 8)
- F**  **5/8" x 8g Pan Pozi BZP (optional)**
Code: F/0414 Quantity = 2 (set of 4)
Quantity = 4 (set of 6)
Quantity = 6 (set of 8)
- G**  **5.0 x 45mm Counter Sunk**
Code: F/0587 Quantity = 16 (set of 4)
Quantity = 24 (set of 6)
Quantity = 32 (set of 8)
- H**  **5.0 x 70mm Pan Head BZP**
Code: F/0591 Quantity = 16 (set of 4)
Quantity = 24 (set of 6)
Quantity = 32 (set of 8)

Tools needed

-  **12mm Spanner**
Quantity = 1

-  **5mm Allen Key**
Quantity = 1

Step 1: Prepare screw sets

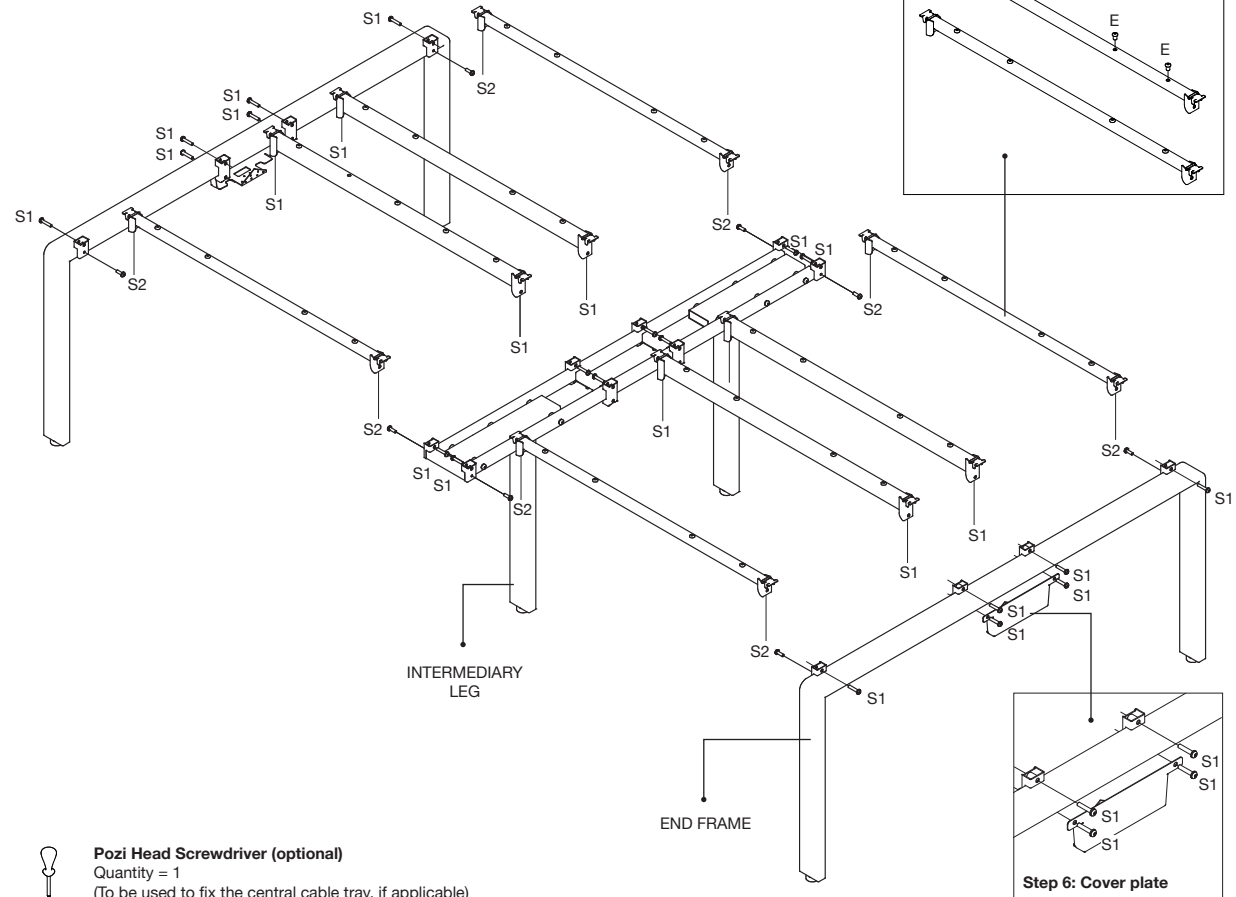
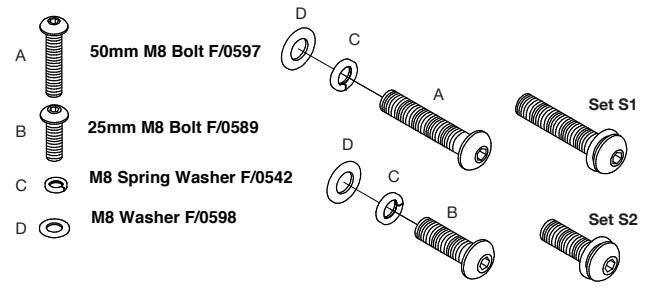

2 People Required

-  **Pozi Head Screwdriver (optional)**
Quantity = 1
(To be used to fix the central cable tray, if applicable)

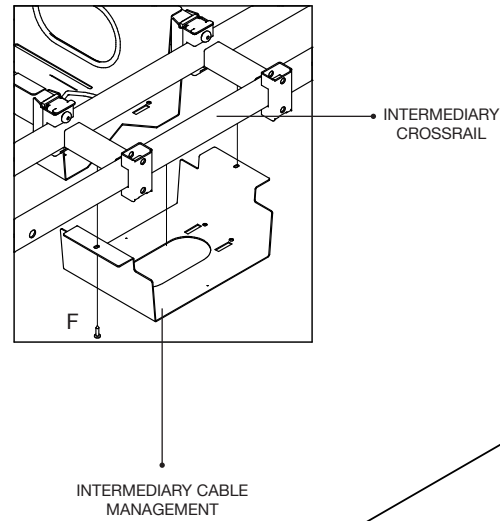
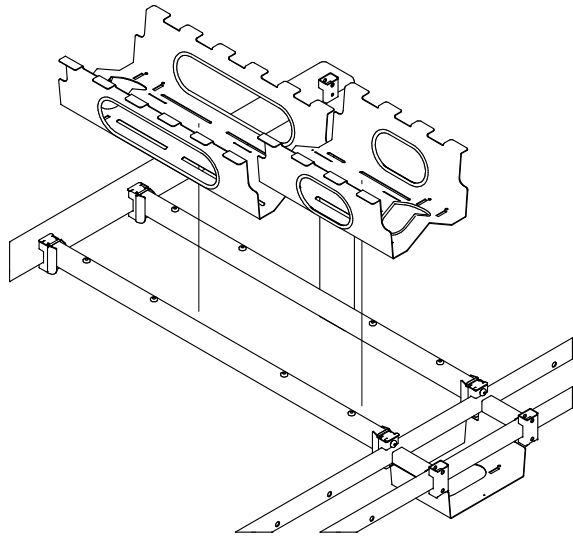

8. Select the various cable management sections and slot onto the centre crossrails, in your desired order, being careful not to cover the intermediary leg (as shown left).
9. If applicable, Offer up the single piece of cable management to the intermediary leg and secure into place using part **F**.
10. **Optional** If adding a vertical cable tower it is recommended to attach at this stage using instruction leaflet 095.

11. Place one top on to the frame at a time and screw into place using part **G** at the front of the desk and part **H** at the rear of the desk.
12. If adding screens secure only two tops onto one side of the frame and slide the screens into place, then add the second set of tops to complete.
13. **WARNING** At this point it is important to adjust the feet to ensure the product is level. To do this simply use a 12mm Spanner to adjust the feet to the appropriate height.
14. The Bench desk is now complete

Step 2: Reversing the intermediary legs

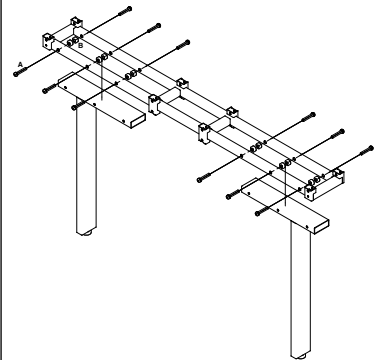

1. Remove the existing screws.
2. Separate the legs from the intermediary frame and reverse.
3. Replace the screws back into their previous positions.
4. Continue to follow instructions from step 2.

