

Important Information

This instruction leaflet can be used for the AURA BENCH rectangular or wave single Bench desk only.

Safety Guide

- Apply manual handling guidelines when building this item.
- Only use component fixings supplied with this item.

Recommendations

Levelling the Bench desk

It is important to adjust the feet at the start and finalise at the end to ensure the product is level. To do this simply use a 12mm Spanner to adjust the feet to the appropriate height. See step 12.

AURABENCH Assembly Instructions

1. Compile Set 1 (S1) and Set 2 (S2) screws, using parts A, B, C and D. These are required to fit the Bench frame together.
2. Using part F, attach the magnetic catches (part E) facing upwards.
3. **Optional** Place part G into the holes in each end frame. Holding one end frame upright offer up the modesty panel and slot onto part G. Twist part H until this locks the two parts in place.
If a modesty panel is not present insert part I.
4. Place part J onto the tubes at each end of the cover plate and slot this into the available holes in the end frame.
5. Now attach the opposite end frame to the modesty panel (if applicable) and cover plate using part G and part H as in step 3.
6. Take the front crossrail and slot into the front brackets. Repeat with the rear crossrail. **Ensuring the holes in the side of the crossrail are pointing towards the cover plate.** Once complete secure the crossrails using sets S1 and S2 (see diagram).

Continue overleaf

Parts Required

- | | | |
|---|--|---|
| A | | M8 x 50mm Skt Button BZP
Code: F/0597 Quantity = 6 |
| B | | M8 x 25mm Skt Button BZP
Code: F/0589 Quantity = 2 |
| C | | M8 Contact Spring Washer
Code: A/0542 Quantity = 8 |
| D | | M8 Plain Washer BZP 8mm x 17 x 1.6
Code: F/0598 Quantity = 8 |
| E | | Magnetic Catch Black
Code: A/0999 Quantity = 2 |
| F | | 5/8" x 8g Pan Pozi BZP
Code: F/0414 Quantity = 4 |
| G | | Minifix Bolt M6 (optional)
Code: F/0433 Quantity = 4 |
| H | | Minifix Alloy Cams (optional: supplied fitted in modesty panel)
Code: F/0434 Quantity = 4 |

- | | | |
|---|--|--|
| I | | Grey Hole Plugs (optional)
Code: F/0585 Quantity = 4 |
| J | | M10 Nylon Washer 10.5 x 20 x 2
Code: F/0614 Quantity = 2 |
| K | | M6 x 12mm Button Screw BZP
Code: F/0603 Quantity = 4 |
| L | | Glide / Buffer Drilled 15mm x 18mm
Code: F/0609 Quantity = 8 |
| M | | 5.0 x 45mm Counter Sunk
Code: F/0587 Quantity = 4 |
| N | | 5.0 x 70mm Pan Head BZP
Code: F/0591 Quantity = 4 |
| O | | Minifix Cover Cap (optional)
Quantity = 4 |

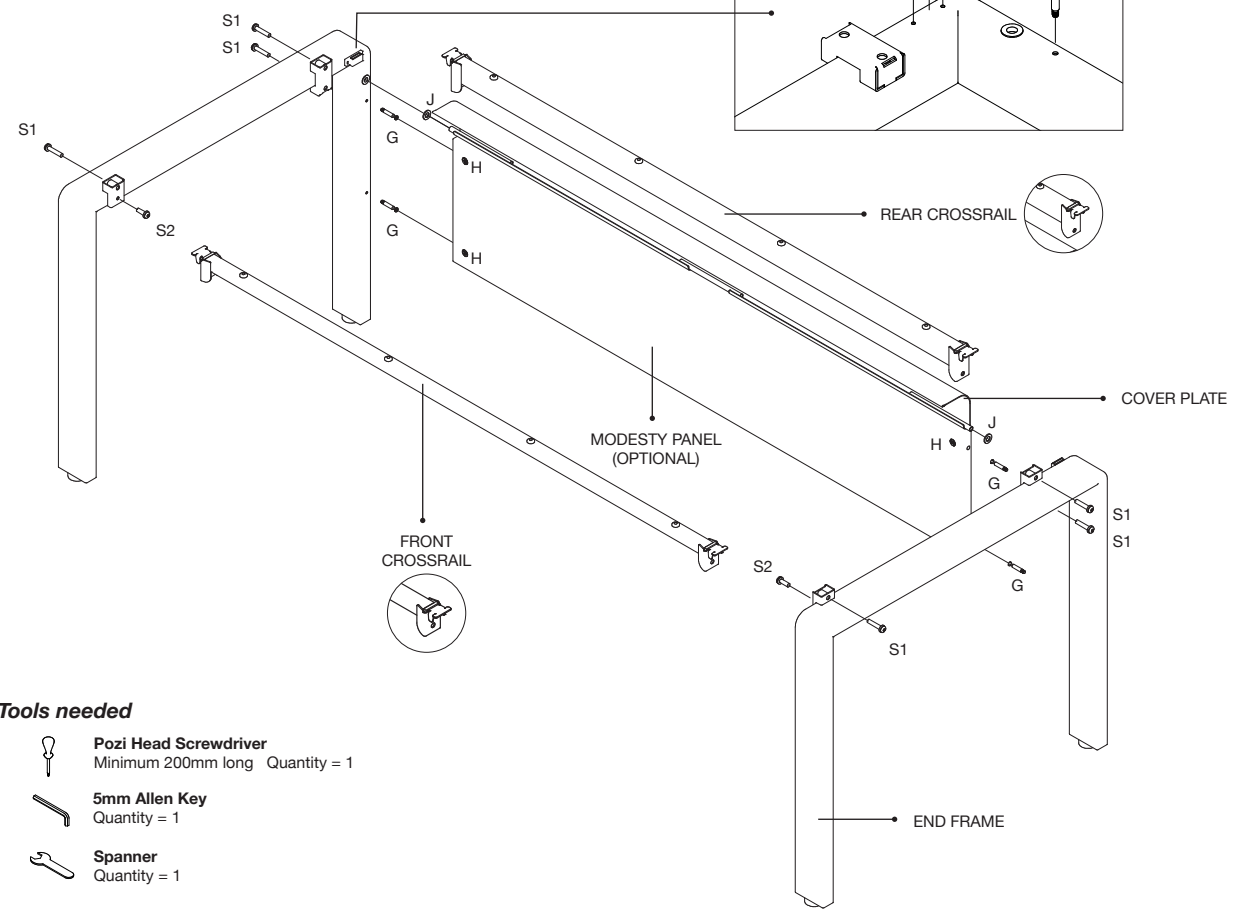
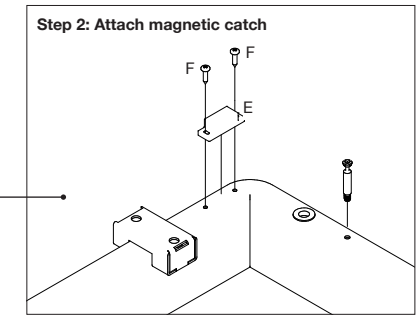
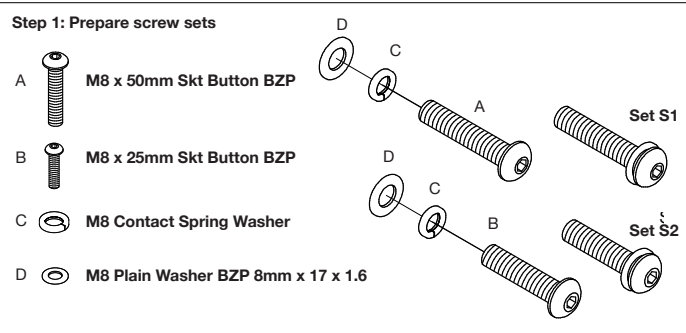

- Tools needed**
- Pozi Head Screwdriver**
Minimum 200mm long Quantity = 1
 - 5mm Allen Key**
Quantity = 1
 - Spanner**
Quantity = 1



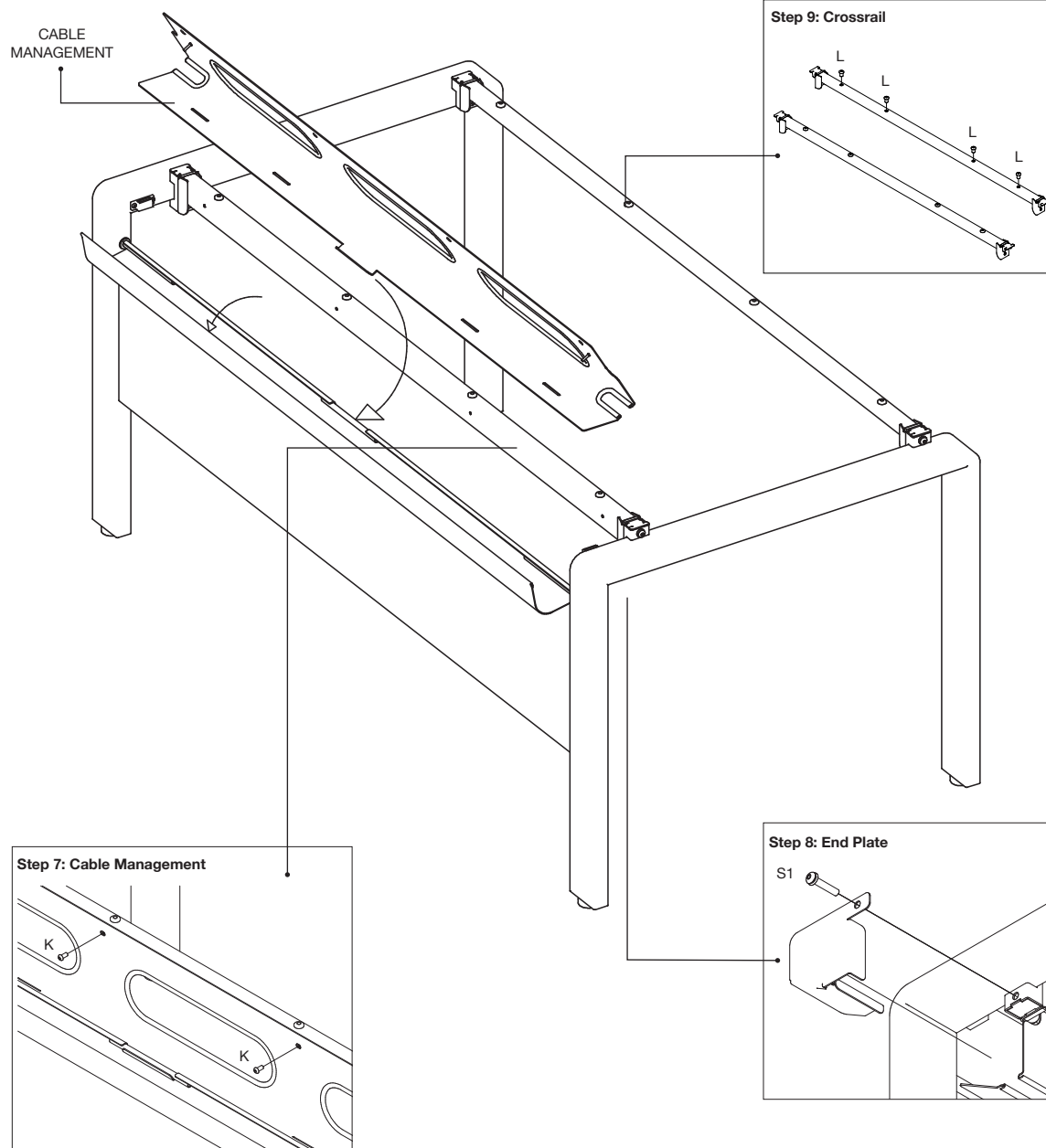

7. Slide the cable management into place ensuring to hook the cable management underneath the cover plate and secure to the rear crossrail using part **K**.
8. Attach the end plates using **S1** screws.
9. Insert glide buffers, part **L**, into the holes in the crossrails.
10. Place the top on to the bench frame and screw into place using part **M** at the front of the desk and part **N** at the rear of the desk.
11. Add cover caps, part **O**, to the modesty panel if present.
12. **WARNING** At this point it is important to adjust the feet to ensure the product is level. To do this simply use a 12mm Spanner to adjust the feet to the appropriate height.
13. The single Bench desk is now complete

