

# Atmosphere Bubble Meeting Point -Trumpet Base Assembly

## Tools required

Pozi head screw driver



Allen key (4mm)

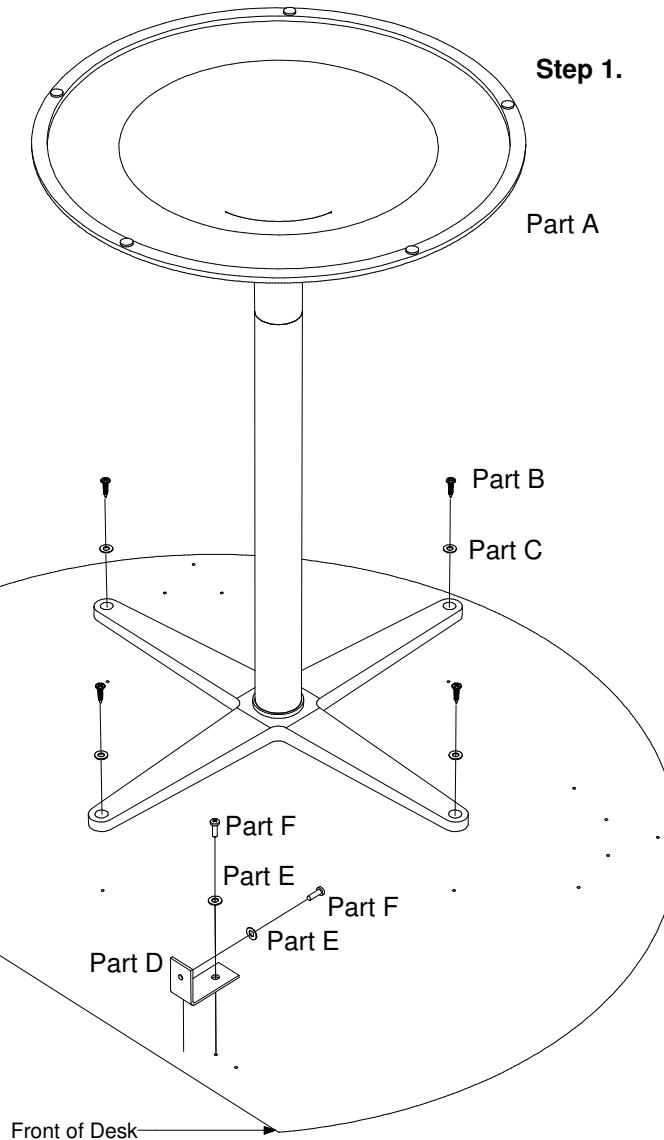
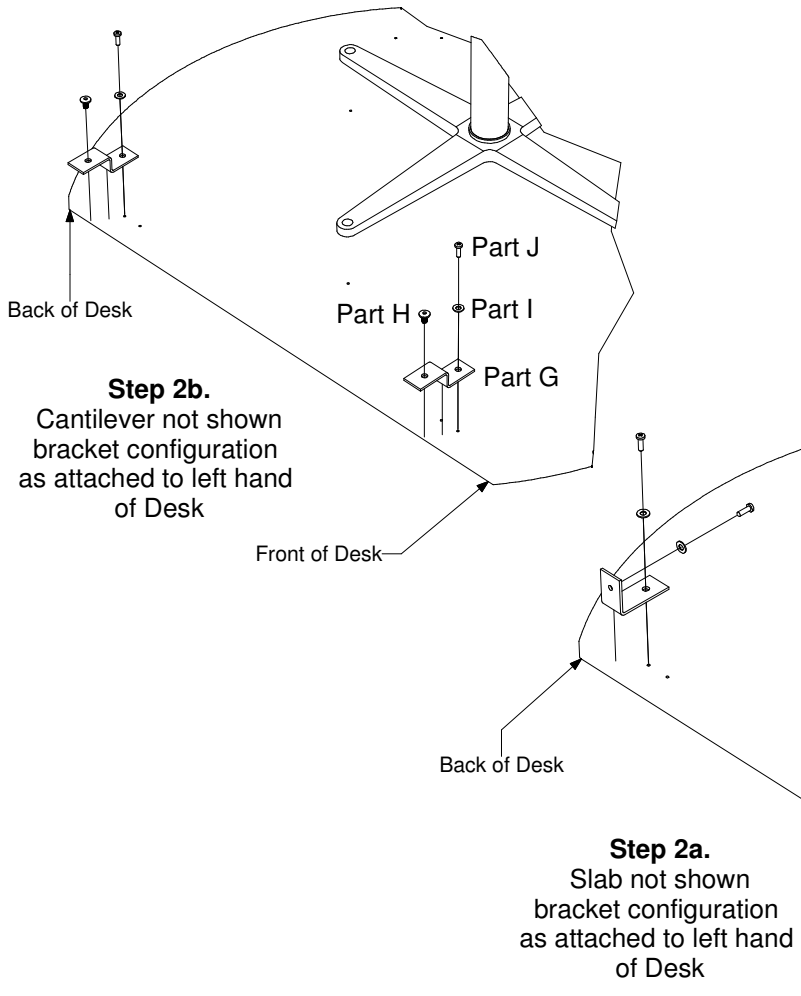

## Assembly steps

### Step 1. Fixing the trumpet base

1. Assemble the trumpet base using the instructions provided.
2. Align the trumpet base (part A) to the holes on the underside of the top.
3. Fix the trumpet base to the top using the four washers (parts C) and screws (parts B) as shown.
4. Stand the product on the base and level the accompanying desks to the height of the Bubble Meeting Point.

### Step 2. Adding the brackets

#### 2a. Follow if fixing to slab ends

1. Position the brackets (parts D) so they are aligned with the correct holes on the top as shown.
2. Ensuring the brackets are pushed firmly against the slabs, fix the brackets to top using the washers (parts E) and screws (parts F) as shown.
3. Fix the brackets to the slabs using the washers (parts E) and screws (parts F) as shown. It may be necessary to create pilot holes before adding the screws.

#### 2b. Follow if fixing to cantilever ends

1. Position the brackets (parts G) so they are aligned with the correct holes on the top and cantilever as shown.
2. Fix the brackets to the cantilever frame using the bolts provided (parts H) as shown.
3. Fix the brackets to the top using the washers (parts I) and screws (parts J) as shown.

# Atmosphere Bubble Meeting Point - Round Leg Assembly

## Tools required

Pozi head screw driver



Allen key (4mm)

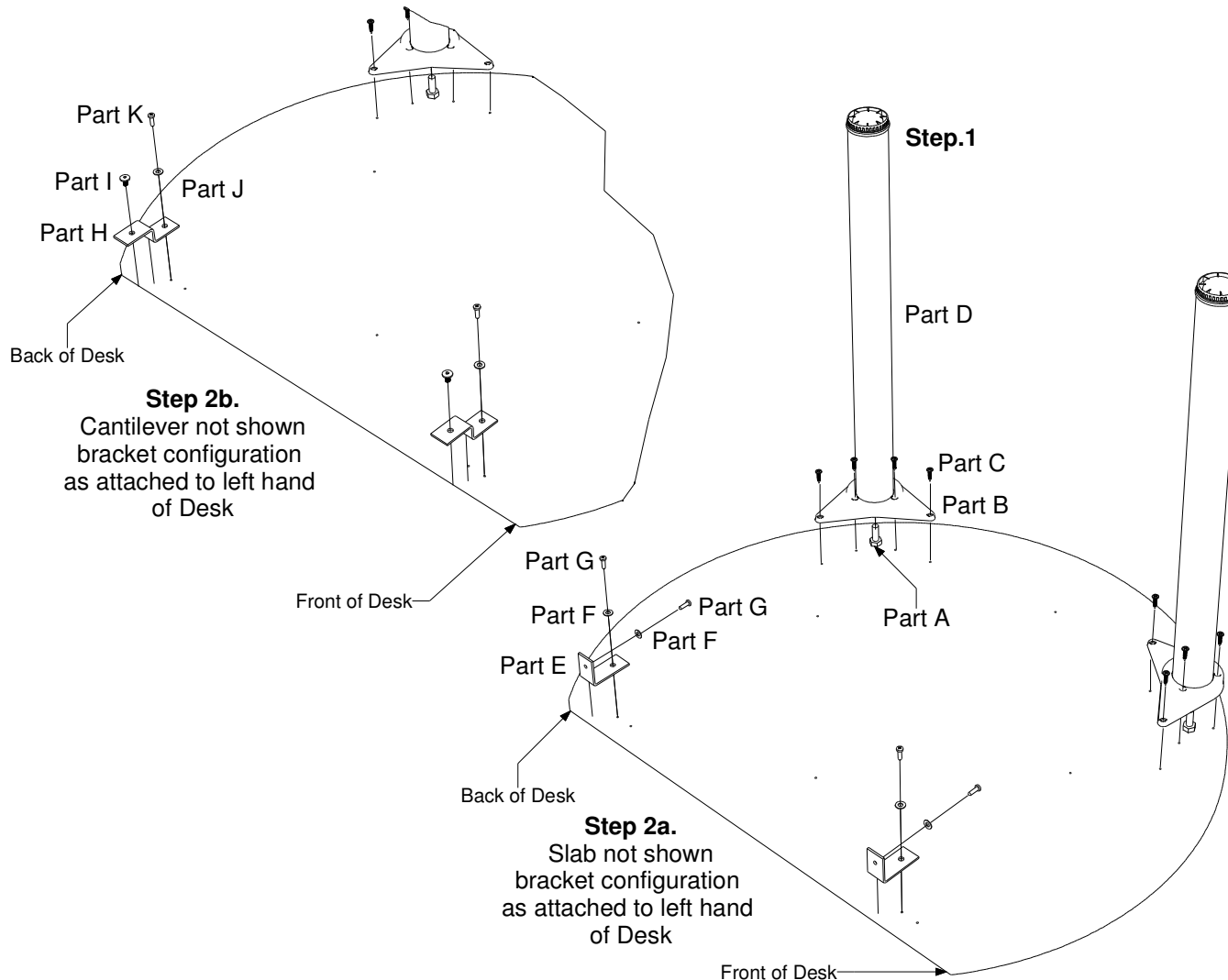

## Assembly steps

### Step 1. Fixing the round legs

1. Place top upside down on a soft clean surface.
2. Position the bolts (parts A) in the underside of the leg plates (parts B) as shown.
3. Align the leg plates (parts B) to the holes on the underside of the top.
4. Fix the leg plates to the top using the screws (parts C) as shown.
5. Screw the legs (parts D) on to the leg plates.
6. Stand the product onto the legs. With one person holding the unsupported edge of the product, level to the height of the desks.

### Step 2. Adding the brackets

2a. Follow if fixing to slab ends. (One person must hold the unsupported edge of the product until fixed).

1. Position the brackets (parts E) so they are aligned with the correct holes on the top as shown.
2. Ensuring the brackets are pushed firmly against the slabs, fix the brackets to top using the washers (parts F) and screws (parts G) as shown.
3. Fix the brackets to the slabs using the washers (parts F) and screws (parts G) as shown. It may be necessary to create pilot holes before adding the screws.

2b. Follow if fixing to cantilever ends. (One person must hold the unsupported edge of the product until fixed).

1. Position the brackets (parts H) so they are aligned with the correct holes on the top and cantilever as shown.
2. Fix the brackets to the cantilever frame using the bolts provided (parts I) as shown.
3. Fix the brackets to the top using the washers (parts J) and screws (parts K) as shown.