

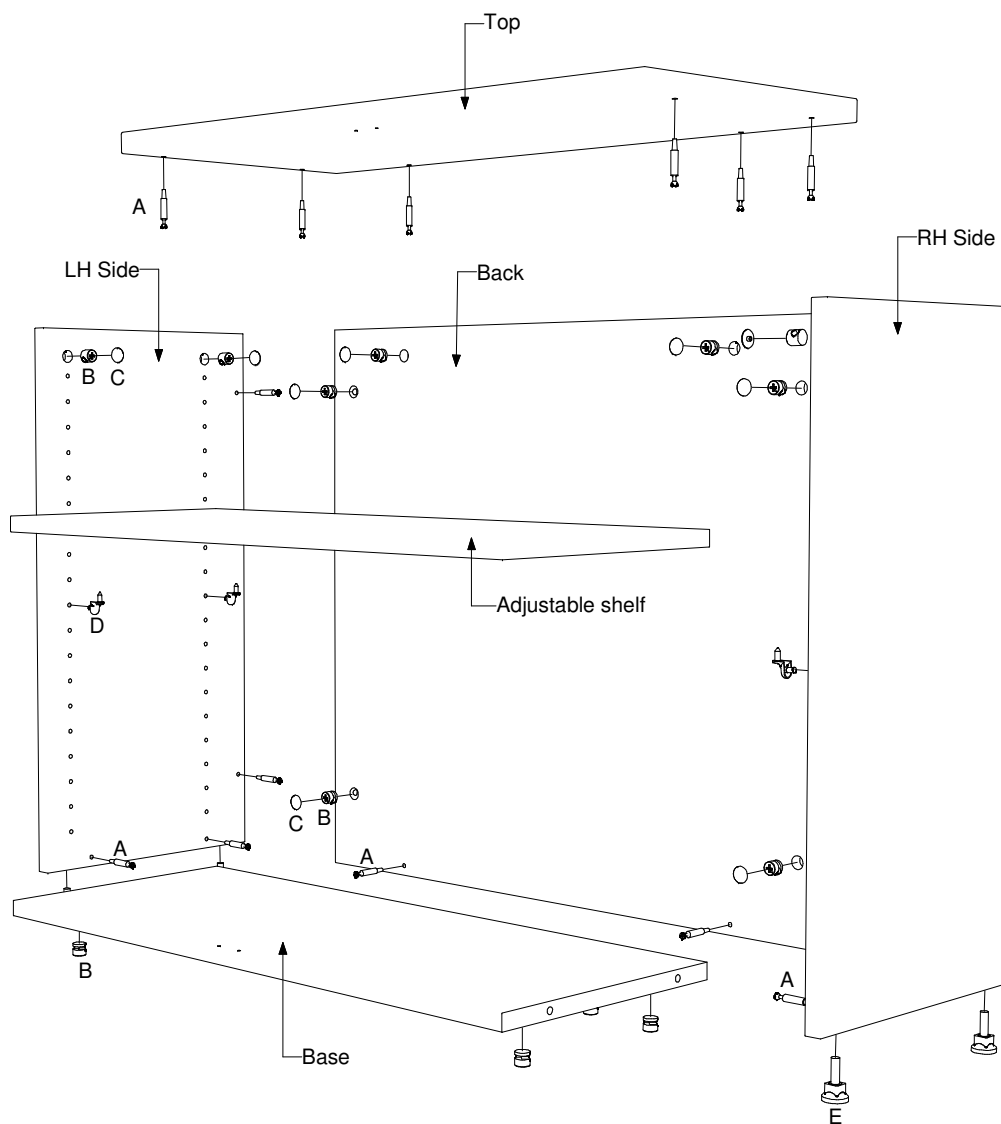

LEE & PLUMPTON

# DHABC1 Adjustable Shelf 800 Wide

Part 1 of 2

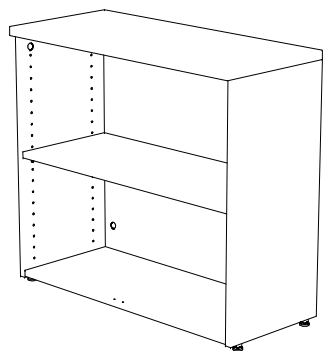

## Fittings supplied

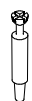

### Part A - F/0532

Minifix bolts chipfast 34x11  
Quantity = 16



### Part B - F/0434

Minifix alloy cams 18mm  
Quantity = 16



### Part C

Minifix cover caps  
Quantity = 10



### Part D - F/0565

Shelf support pin  
Quantity = 4

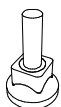

### Part E

Adjustable feet  
Quantity = 4

## Tools required



Pozi head screw driver

## Assembly steps













1. Firstly prepare the base, sides, back and top panels by adding the appropriate quantities of parts A and B (when adding parts B ensure the arrows face out and the holes are free from debris.). The shelf require no preparation.
2. Lay the back down on a soft surface with the fittings facing up.
3. Fit the base to the back via parts A on the back and parts B on the base, tighten parts B that connect the two panels.
4. Next add the sides. To do this it may be necessary to lift the back off the ground slightly. This will allow parts A on the sides to connect with parts B on the back and base. When in place tighten parts B that connect the panels.
5. To add the top, lift the assembly off the ground slightly and connect via parts A on the top and parts B on the sides and back. Tighten parts B that connect the panels.
6. Screw the feet (part E) into the sides.
7. Stand the bookcase upright onto its feet.
8. To fit the shelf, insert the peg of parts D into the sides (4 per shelf) ensuring the pins align to fit into the shelf, then lower the shelf on to the supports.
9. Finish the product by adding parts C in the appropriate places. These are not required on the base panel.



LEE & PLUMPTON

# DHABC 800 Wide Doors

## Fittings supplied

-  **Part A - A/0559**  
Cupboard lock striker plate  
Quantity=1
-  **Part B - A/0648**  
Cupboard door lock  
Quantity=1
-  **Part C - D/0362**  
Lock rosette  
Quantity=1
-  **Part D - A/0552**  
Cupboard door bolt  
Quantity=2
-  **Part E - F/0442**  
5/8"x4g c/snk BZP  
Quantity=1
-  **Part F - F/0470**  
3/4" x 6g c/snk pozi BZP  
Quantity=8
-  **Part G - A/0622**  
40mm angled striker plate  
Quantity=2
-  **Part H - A/0620**  
Bow handle brushed nickel  
Quantity=2
-  **Part I - F/0468**  
M4 x 23mm handle screw  
Quantity=4
-  **Part J - F/0412**  
5/8"x6g C/Snk Pozi BZP  
Quantity=12
-  **Part K - A/0592**  
Hinge 100 opening  
Quantity=4
-  **Part L - A/0593**  
Hinge clip plate  
Quantity=4
-  **Part M - A/0594**  
Hinge cover plate nickel  
Quantity=4

## Part 2 of 2

### Step 1 - Preparing the doors

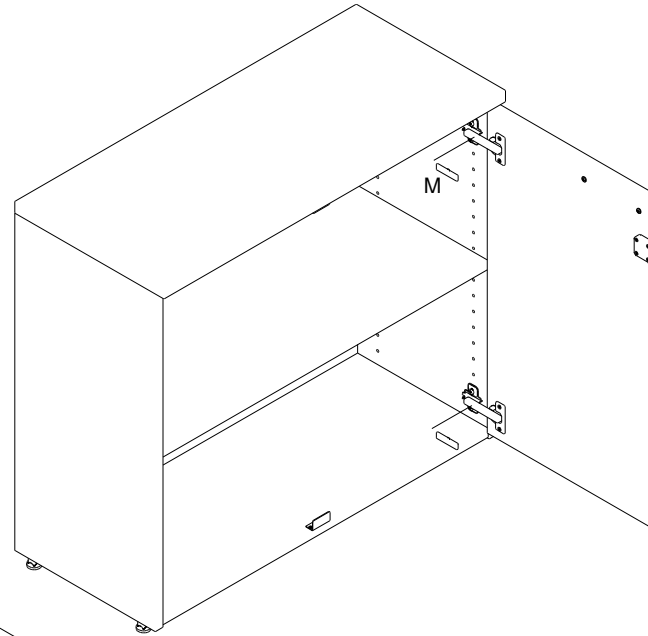
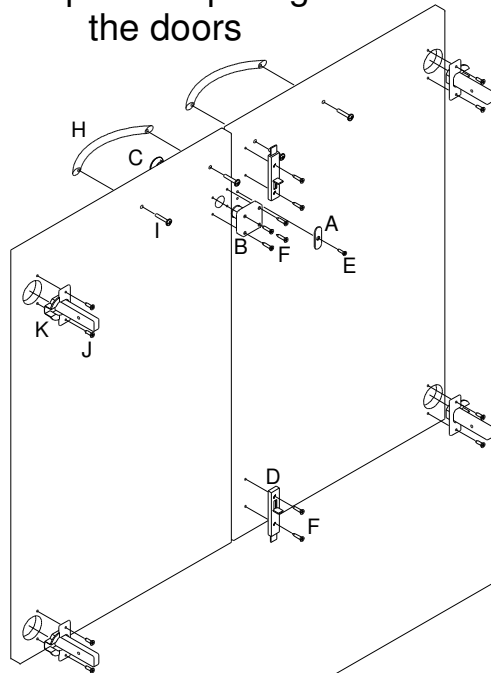

### Step 3 - Attaching the doors and hinge cover plates.

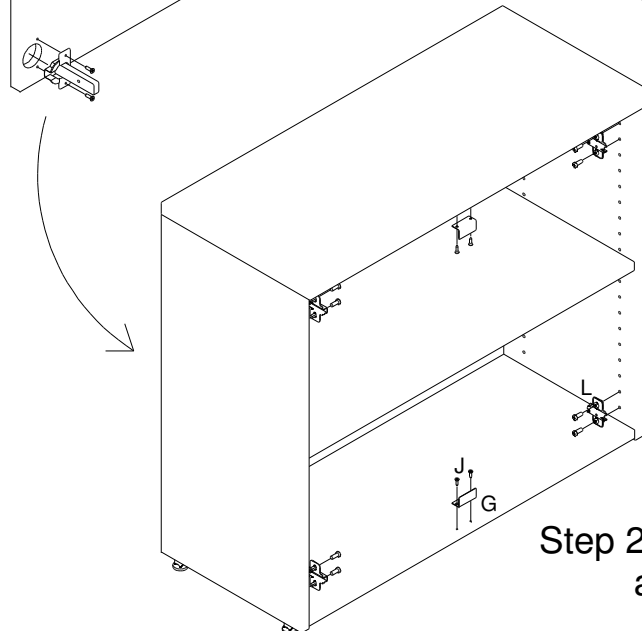

### Step 2 - Adding the hinge clip plates and angled striker plates.



## Tools required

Pozi head screw driver

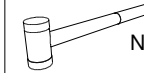

Nylon hammer

## Assembly steps

### Step 1

Lay the RH door down on a soft surface with the hinge holes facing down, gently bang/push part C (x1) into the lock hole.

Lay both doors down with the hinge holes facing up. Fix the lock (part B), cupboard door bolts (part D) and hinges (part K) with the screws as shown, taking care all fittings are attached in the correct orientation.

Finally add the handles (part H), this may be easier if the area to which the handle is fixed overhangs a raised surface.

The doors are now ready to be added to the adjustable bookcase.

### Step 2

Add part L to the bookcase using the screws provided with the plates. (Ensure the screws are positioned centrally to the screw slots and the arrows on the plates are facing out).

Next attach the striker plates (part G) to the bookcase using the screws (part J).

### Step 3

Firstly attach the doors by clipping the hinges onto the hinge clip plates (parts L).

It may be necessary to adjust the doors alignment by tweaking the screws on the hinges. Before doing this it is recommended to attach all doors.

Finally add the hinge cover plates (part M) to finish the hinges.

Example of finished unit with doors